

## **FnIO G-Series:**

### ***GN-9371 / GN-9372 / GN-9373***

#### ***Modbus Programmable I/O***



# Specification

**DOCUMENT CHANGE SUMMARY**

<b>REV.</b>	<b>PAGES</b>	<b>REMARKS</b>	<b>DATE</b>	<b>Editor</b>
Preliminary	29	First Preliminary	Apr 23, 2018	MK, Park

# Specification

## Table of Contents

Table of Contents.....	3
1.ENVIRONMENT SPECIFICATION.....	5
2.GN-9371/9372/9373 (G-SERIES PROGRAMMABLE I/O).....	6
2.1.GN-9371/9372/9373 Specification.....	6
2.2.GN-9371/9372/9373 Ethernet connection specification.....	7
2.3.GN-9371/9372/9373 Wiring Diagram.....	8
2.4.GN-9371/9372/9373 LED Indicator.....	9
2.4.1.LED Indicator.....	9
2.4.2.MOD (Module Status LED).....	9
2.4.3.NET (Network Status LED).....	9
2.4.4.RUN (PLC Run/Stop Status LED).....	9
2.4.5.IOS LED (Expansion Module Status LED).....	10
2.4.6.Field Power LED (Field Power Status LED).....	10
2.5.GN-9371/9372/9373 Electrical Interface.....	11
2.5.1.RJ-45 Socket.....	11
2.5.2.RS-232/RS-485 Port for MODBUS/RTU, Touch Panel or IOGuide.....	11
2.5.3.Toggle Switch and Push Botton.....	11
2.6.GN-9371/9372/9373 Web-Server .....	12
3.MODBUS/RTU INTERFACE.....	14
3.1.Surpported MODBUS Function Codes.....	14
3.1.1.1 (0x01) Read Coils.....	14
3.1.1.2 (0x02) Read Discrete Inputs.....	15
3.1.1.3 (0x03) Read Holding Resgisters.....	15
3.1.1.4 (0x04) Read Input Resgisters.....	16
3.1.1.5 (0x05) Write Single Coil.....	16
3.1.1.6 (0x06) Write Single Register.....	17
3.1.1.7 (0x08) Diagnostics.....	17
3.1.1.15 (0x0F) Write Multiple Coils.....	20
3.1.1.16 (0x10) Write Multiple Resgisters.....	20
3.1.1.23 (0x17) Read/Write Multiple Resgisters.....	21
3.1.1.11.Error Response.....	22
3.2.MODBUS Special Register Map.....	23
3.2.1.Adapter Resgister Mapping.....	23

# Specification

---

<a href="#"><u>3.2.2.Adapter Identification Special Resgister (0x1000, 4096)</u></a> .....	23
<a href="#"><u>3.2.3.Adapter Information Special Register (0x1100, 4352)</u></a> .....	24
<a href="#"><u>3.2.4.Adapter Setting Special Register (0x1600, 5632)</u></a> .....	25
<a href="#"><u>3.2.5.Expasion Slot Information Special Resister (0x2000, 8192)</u></a> .....	26
<a href="#"><u>3.3.Surppoted MODBUS Function Codes</u></a> .....	29

# Specification

## 1. ENVIRONMENT SPECIFICATION

<b>Environmental specification</b>	
Operating Temperature	-40°C~70°C (TBD)
UL Temperature	-20°C~60°C
Storage Temperature	-40°C~85°C
Relative Humidity	5% ~ 90% non-condensing
Mounting	DIN rail
<b>Vibration Resistance</b>	
EMC Resistance Burst/ESD	IEC 60068-2-27
Installation Pos. / Protect. Class	Based on IEC 60068-2-6 Sine Vibration 5 ~ 25Hz : 1.6mm 25 ~ 300Hz : 4g Sweep Rate : 1 Oct/min, 20 cycles Random Vibration 10 ~ 40Hz : 0.0125g <sup>2</sup> /Hz 40 ~ 100Hz : 0.0125 → 0.002g <sup>2</sup> /Hz 100 ~ 500Hz : 0.002g <sup>2</sup> /Hz 500 ~ 2000Hz : 0.002 → 1.3 x 10 <sup>-4</sup> g <sup>2</sup> /Hz Test time : 1 hours for each test
Product Certifications	EN 61000-6-2 : 2005 EN 61000-6-4/A11 : 2011
Installation Pos. / Protect. Class	Variable/IP20
Product Certifications	CE AoC, FCC, KC, UL, RoHS2 (TBD)

# Specification

## 2. GN-9371/9372/9373 (G-SERIES PROGRAMMABLE I/O)

### 2.1. GN-9371/9372/9373 Specification

Items		Specification	
<b>Programmable Specification</b>			
Programming		CoDeSys V3.5.11.0	
Program Memory	GN-9371 *	512 KBytes	
	GN-9372/9373	16 MBytes	
Data Memory	GN-9371	96 KBytes	IO Input: %IW0 ~%IW2047 (2048 words) IO Output: %QW0 ~%QW2047 (2048 words) Memory: %MW0 ~ %MW8191 (8192 words)
	GN-9372/9373	16 MBytes	
Non-Volatile Memory	GN-9371	4 KBytes (Retain : 2 KBytes, Flag : 2 KBytes)	
	GN-9372/9373	64 KBytes (Retain : 32 KBytes, Flag : 32 KBytes)	
Run-Time System		Multiple PLC Tasks	
Program Languages		IEC 61131-3 (LD, IL, ST, FBD, SFC)	
OPC-Server	GN-9371	Not supporting	
	GN-9372/9373	DA	
Webvisualization	GN-9371/9372	Not supporting	
	GN-9373	Supporting	
RTC	GN-9371	Retain Time : < 1 day (TBD)	Accuracy : < 2min/month (TBD)
	GN-9372/9373	Retain Time : < 6 day (TBD)	
Max. Task		10	
Max. Cycle Task		10	
Max. Status Task		10	
Process Time	GN-9371	1usec (90 Instructions)	
	GN-9372/9373	7usec (90 Instructions)	
<b>Interface Specification</b>			
Adapter Type		Master & Slave Node (Modbus TCP, Modbus RTU)	
Max. Expansion Module		63 Slots	
Max. Data Size(Input+Output)		Max 128Byte each slot	
Max. Nodes		Limited by Ethernet Specification	
Baud rate		10/100Mbps, Auto-negotiation, Full Duplex	
Ethernet Interface		RJ-45 socket * 2pcs	
Ethernet Protocol**		Modbus/TCP, Modbus/UDP, SNTP HTTP (Webvisualization***, Web-Server), DHCP/BOOTP, OPC-server	
Max. Socket		24 (UDP: 8, TCP: 16, TCP LISTEN: 10)	
Serial Interface		RS232/RS485 2port (supporting Touch Panel)	
Serial Protocol		Modbus/RTU / Baud Rate : 2400~115200 bps (Default: 115200 bps)	
Indicator		6 LEDs 1 Green/Red, Module Status (MOD) 1 Green/Red, Network Status (NET) 1 Green/Red, PLC Run/Stop Status (RUN) 1 Green/Red, Expansion I/O Module Status (IOS) 1 Green, System Power Status 1 Green, Field Power Status	

# Specification

General specification	
System Power	Supply voltage : 24Vdc nominal Supply voltage range : 15~32Vdc Protection : Output current limit (Min. 1.5A) / Reverse polarity protection
Power Dissipation	110mA typical @ 24Vdc
Current for I/O Module	1.5A @ 5Vdc
Isolation	System power to internal logic : Non-isolation System power I/O driver : Isolation
Field Power	Supply voltage : 24Vdc typical (Max. 32Vdc) * Field Power Range is different depending on IO Module series. Refer to IO Module's Specification.
Max. Current Field Power Contact	DC 10A Max
Weight	<167g
Module Size	54mm x 99mm x 70mm
Environment Condition	Refer to '1. Environment Specification'

\* GN-9371 is an economic version derived from GN-9372.

\*\*\* Webvisualization cannot be supported in Internet Explorer.

## 2.2. GN-9371/9372/9373 Ethernet connection specification

Function*	Model	Max. number of concurrent communications
Webvisualization	GN-9373 only	One for each functions are available at the same time
ARTI (OPC-server)	GN-9372/73	
CoDeSys link	GN-9371/72/73	
Network-variable	GN-9371/72/73	
Modbus/TCP Master	GN-9371/72/73	5 Modbus/TCP Slaves can be connected (TBD)
Modbus/TCP Slave	GN-9371/72/73	16 Modbus/TCP Masters can be connected (TBD)
Web-server	GN-9371/72/73	16 clients can be opened (TBD)

\* While using these functions, 16 sockets (TBD) are available at the same time.

# Specification

## 2.3. GN-9371/9372/9373 Wiring Diagram

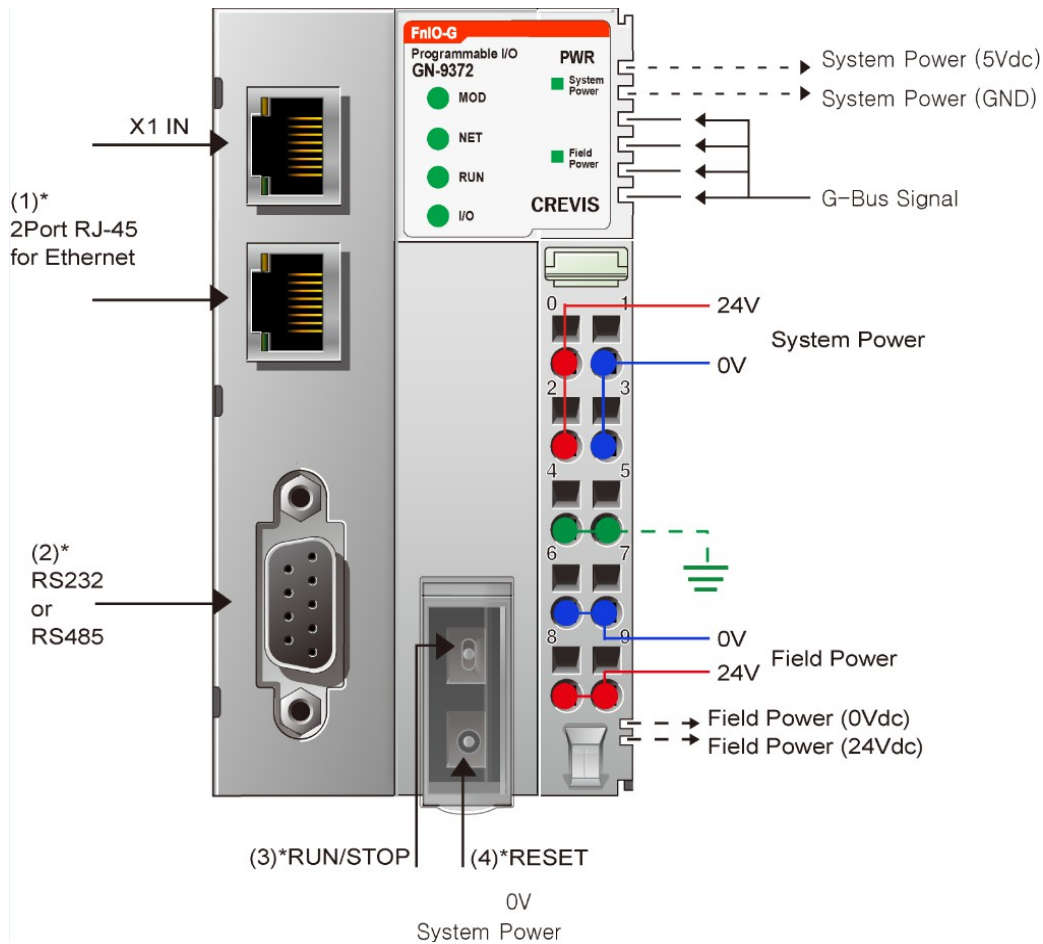

Pin No.	Signal Description	Signal Description	Pin No.
0	System Power, 24V	System Power, Ground	1
2	System Power, 24V	System Power, Ground	3
4	F.G	F.G	5
6	Field Power, Ground	Field Power 0V, Ground	7
8	Field Power, 24V	Field Power, 24V	9

**\* Warning:** The system power must not be connected with field power. Use separate voltage supplies.



# Specification

## 2.4. GN-9371/9372/9373 LED Indicator

### 2.4.1. LED Indicator

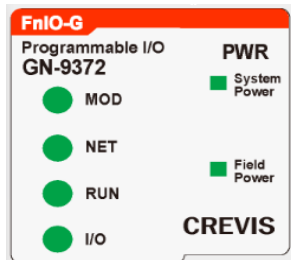

LED No.	LED Function / Description	LED Color
MOD	Module Status	Green/Red
NET	Network Status	Green/Red
RUN	PLC Run/Stop Status	Green/Red
IOS	Expansion Module Status	Green/Red
Field Power	Field Power Enable	Green
System Power	System Power Enable	Green

### 2.4.2. MOD (Module Status LED)

Status	LED is	To indicate
Not Powered	OFF	Power is not supplied to the unit.
Normal, Operational	Green	The unit is operating in normal condition.
Device in Standby	Blinking Green	The EEPROM parameter is not initialized yet. Serial Number is zero value (0x00000000)
IAP Mode	Toggling Green & Red	IAP Mode : Available for firmware download using FireFox.
Unrecoverable Fault	Red	The unit has occurred unrecoverable fault in self-testing. - Firmware fault

\* The IP Address to access IAP web-server during IAP Mode: 192.168.100.10 (Recommended to use FireFox)

### 2.4.3. NET (Network Status LED)

Status	LED is	To indicate
Off-line	OFF	Network Offline.
On-line (Connect)	Green	On-line Mode and network is connected.
Error	Red	Network Error
Diagnorstic	Blinking Red	Diagnostic Mode

\*Blinking Green MOD & NET LED: Bootp/DHCP is requesting for new IP address.

(You can change the IP setting mode. Please refer to specification.)

### 2.4.4. RUN (PLC Run/Stop Status LED)

Status	LED is	To indicate
Not programmed	OFF	The unit is not programmed or not powered.
Run	Green	PLC Run
Stop	Blinking Green	PLC Stop
Program Error	Blinking Red	PLC program error

# Specification

## 2.4.5. IOS LED (Expansion Module Status LED)

Status	LED is	To indicate
Not Powered No Expansion Module	OFF	Device has no expansion module or may not be powered.
On-line, Do not Exchanging I/O	Blinking Green	I/O Communication is normal but does not exchanging I/O data. (Passed the expansion module configuration)
Connection, Run Exchanging I/O	Green	Exchanging I/O data.
Connection Fault during Exchanging I/O	Blinking Red	One or more expansion module occurred in fault state. <ul style="list-style-type: none"> <li>- Changed expansion module configuration.</li> <li>- Communication failure.</li> <li>- Overflowed Input/Output size.</li> </ul>
Expansion Configuration Failed	Red	Failed to initialize expansion module. <ul style="list-style-type: none"> <li>- Detect invalid expansion module ID.</li> <li>- Too many expansion module.</li> <li>- Initial protocol failure.</li> <li>- Mismatch vendor code between adapter and expansion module.</li> </ul>

## 2.4.6. Field Power LED (Field Power Status LED)

Status	LED is	To indicate
Not supplied field power	OFF	Not supplied 24Vdc field power.
Supplied field power	Green	Supplied 24Vdc field power.

## 2.5. GN-9371/9372/9373 Electrical Interface

### 2.5.1. RJ-45 Socket

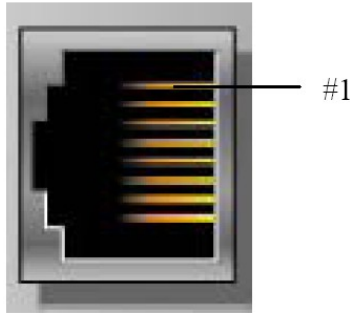

Shielded RJ-45 Socket

RJ-45	Signal Name	Description
1	TD+	Transmit +
2	TD-	Transmit -
3	RD+	Receive +
4	-	
5	-	
6	RD-	Receive -
7	-	
8	-	
Case	Shield	

### 2.5.2. RS-232/RS-485 Port for MODBUS/RTU, Touch Pannel or IOGuide

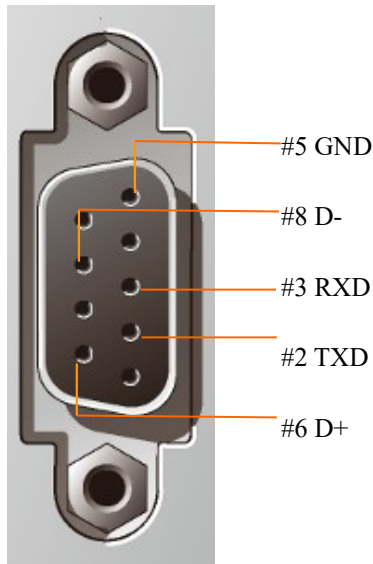

D-Sub 9Pin		
Pin#	Signal Name	Description
1	-	
2	TXD	RS232 TXD
3	RXD	RS232 RXD
4	-	
5	GND	RS232 GND
6	D+	RS485 D+
7	-	
8	D-	RS485 D-
9	-	

### 2.5.3. Toggle Switch and Push Button

Toggle Switch Status	Module is	Description
UP	RUN	PLC Run
DOWN	STOP	PLC Stop

Push Button	Module is	Description
Push and detach	Reset	PLC Reset and Stop
Push for 5sec and Power Reset	PLC Reset	Erase PLC user program and Retain memory
Push for 20sec and Power Reset	Factory Reset	Erase PLC user program and PLC parameter reset
Push hold and Power Reset	IAP mode	Firmware download via FireFox.

# Specification

## 2.6. GN-9371/9372/9373 Web-Server

\* Web-Server Address : <http://IP/setup.htm> (<http://192.168.100.25/setup.htm>)

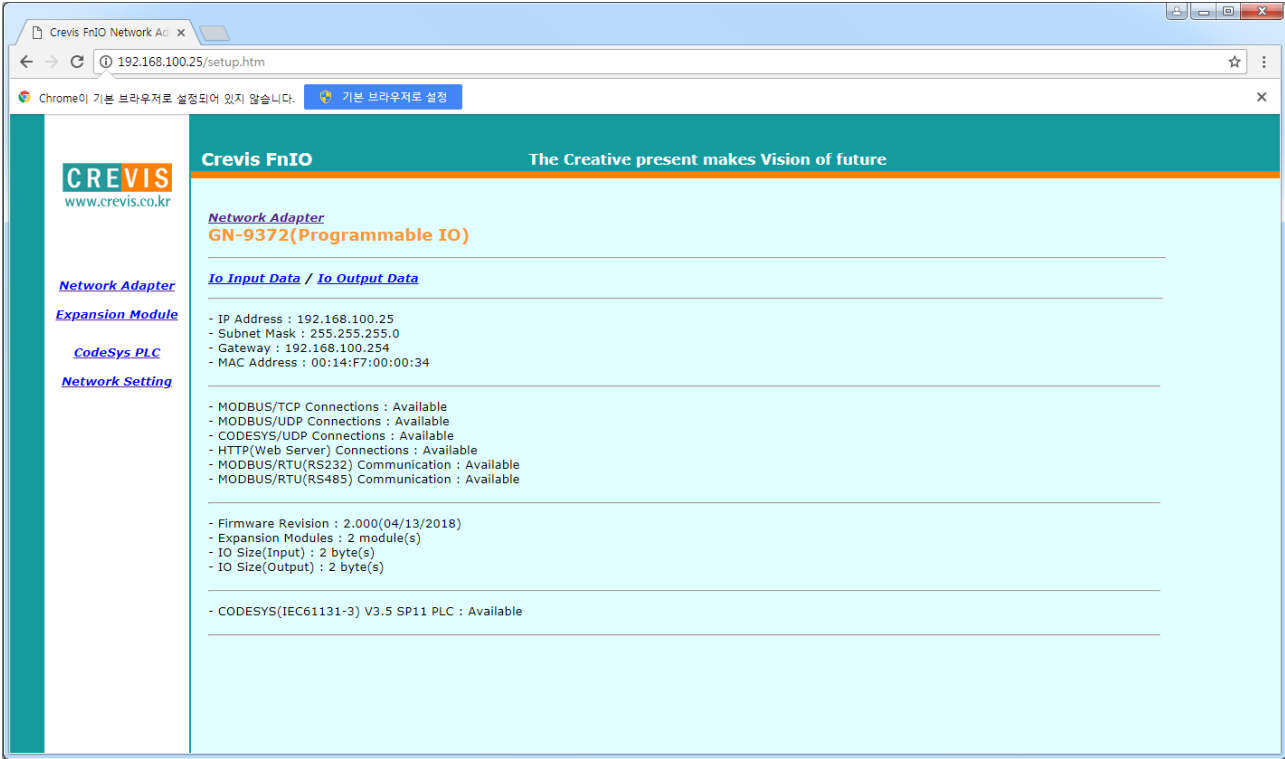

- Showing the expansion modules that attached to PIO

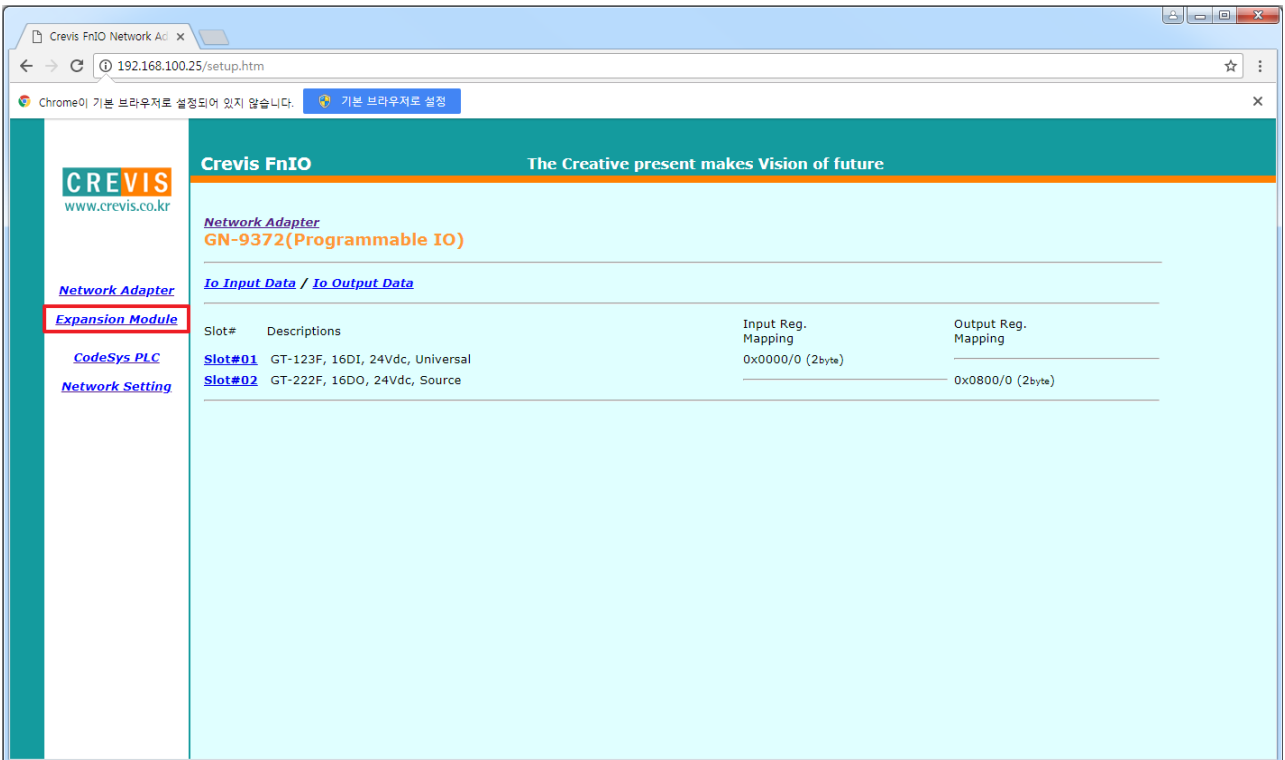

# Specification

- Showing CoDeSys PLC programming information and RTC time setting. RTC time can be changeable in this page.

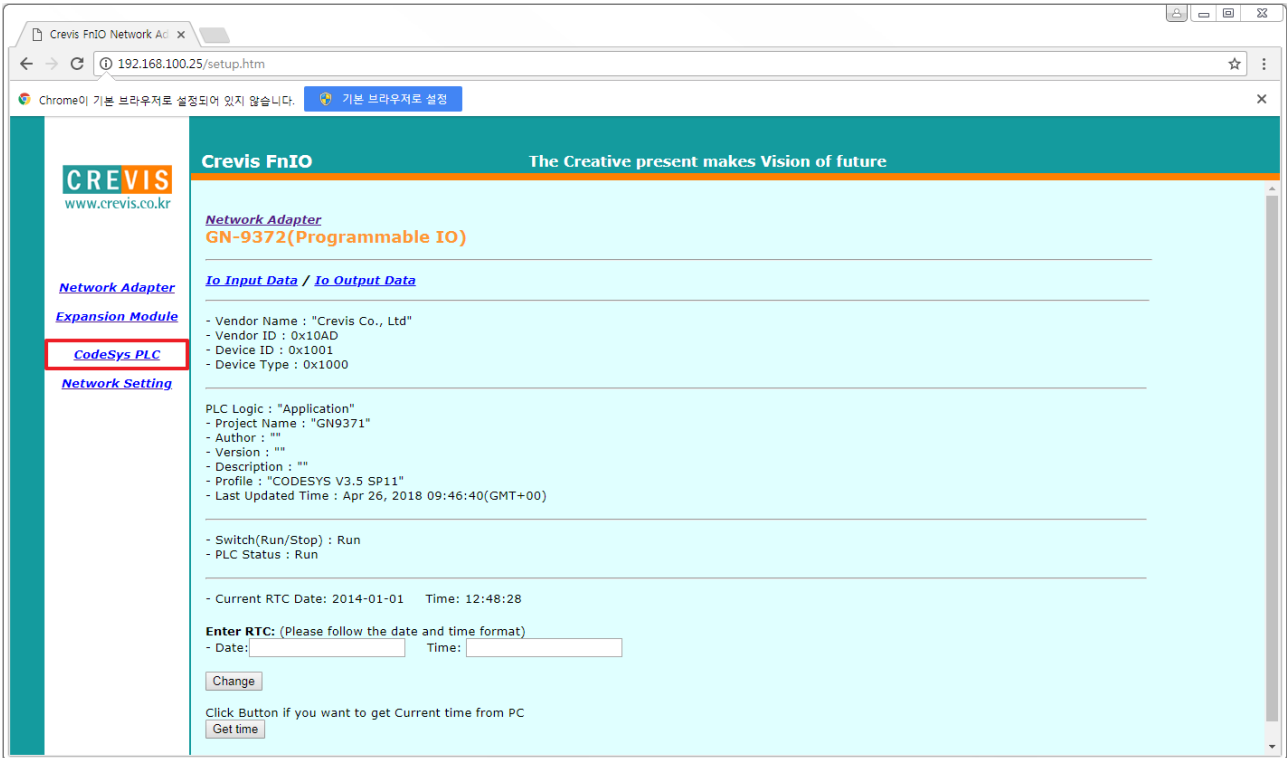

- Network setting can be changeable in this page.

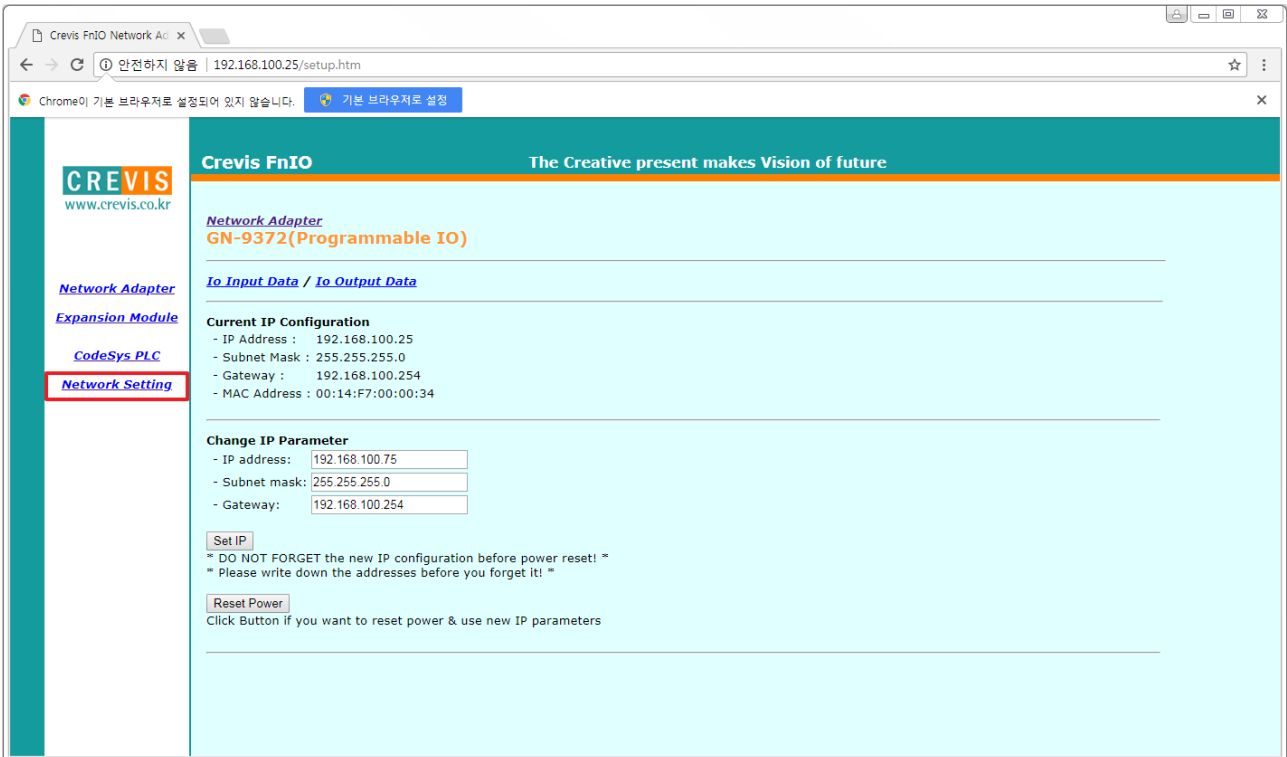

## 3. MODBUS/RTU INTERFACE

### 3.1. Supported MODBUS Function Codes

Function Code	Function	Description
1(0x01)	Read Coils	Read output bit
2(0x02)	Read Discrete Inputs	Read input bit
3(0x03)	Read Holding Registers	Read output word
4(0x04)	Read Input Registers	Read input word
5(0x05)	Write Single Coil	Write one bit output
6(0x06)	Write Single Register	Write one word output
8(0x08)	Diagnostics	Read diagnostic register
15(0x0F)	Write Multiple Coils	Write a number of output bits
16(0x10)	Write Multiple registers	Write a number of output words
23(0x17)	Read/Write Multiple registers	Read a number of input words /Write a number of output words

- Refer to MODBUS APPLICATION PROTOCOL SPECIFICATION V1.1a

#### 3.1.1. 1 (0x01) Read Coils

This function code is used to read from 1 to 2000 contiguous status of coils in a remote device. The Request PDU specifies the starting address, i.e. the address of the first coil specified, and the number of coils. In the PDU Coils are addressed starting at zero. Therefore coils numbered 1-16 are addressed as 0-15. The coils in the response message are packed as one coil per bit of the data field. Status is indicated as 1= ON and 0= OFF.

- Request**

Field name	Example
Function Code	0x01
Starting Address Hi	0x10
Starting Address Lo	0x00
Quantity of Outputs Hi	0x00
Quantity of Outputs Lo	0x0A

- Response**

Field name	Example
Function Code	0x01
Byte Count	0x02
Output Status	0x55
Output Status	0x02

- In case of address 0x1015~0x1000 output bit value: 10101010\_01010101.

# Specification

## 3.1.2. 2 (0x02) Read Discrete Inputs

This function code is used to read from 1 to 2000 contiguous status of discrete inputs in a remote device. The Request PDU specifies the starting address, i.e. the address of the first input specified, and the number of inputs. In the PDU Discrete Inputs are addressed starting at zero. Therefore Discrete inputs numbered 1-16 are addressed as 0-15.

The discrete inputs in the response message are packed as one input per bit of the data field.

Status is indicated as 1= ON; 0= OFF.

- **Request**

Field name	Example
Function Code	0x02
Starting Address Hi	0x00
Starting Address Lo	0x00
Quantity of Inputs Hi	0x00
Quantity of Inputs Lo	0x0A

- **Response**

Field name	Example
Function Code	0x02
Byte Count	0x02
Input Status	0x80
Input Status	0x00

- In case of address 0x0015~0x0000 input bit value: 00000000\_10000000.

## 3.1.3. 3 (0x03) Read Holding Resgisters

This function code is used to read the contents of a contiguous block of holding registers in a remote device. The Request PDU specifies the starting register address and the number of registers.

The register data in the response message are packed as two bytes per register, with the binary contents right justified within each byte. For each register, the first byte contains the high order bits and the second contains the low order bits.

- **Request**

Field name	Example
Function Code	0x03
Starting Address Hi	0x08
Starting Address Lo	0x00
Quantity of Register Hi	0x00
Quantity of Register Lo	0x02

- **Response**

Field name	Example
Function Code	0x03
Byte Count	0x04
Output Register#0 Hi	0x11
Output Register#0 Lo	0x22
Output Register#1 Hi	0x33
Output Register#1 Lo	0x44

- In case of address 0x0800, 0x0801 output register value: 0x1122, 0x3344.

# Specification

## 3.1.4. 4 (0x04) Read Input Registers

This function code is used to read from 1 to approx. 125 contiguous input registers in a remote device. The Request PDU specifies the starting register address and the number of registers. The register data in the response message are packed as two bytes per register, with the binary contents right justified within each byte. For each register, the first byte contains the high order bits and the second contains the low order bits.

- **Request**

Field name	Example
Function Code	0x04
Starting Address Hi	0x00
Starting Address Lo	0x00
Quantity of Register Hi	0x00
Quantity of Register Lo	0x02

- **Response**

Field name	Example
Function Code	0x03
Byte Count	0x04
Input Register#0 Hi	0x00
Input Register#0 Lo	0x80
Input Register#1 Hi	0x00
Input Register#1 Lo	0x00

- In case of address 0x0000, 0x0001 input register value: 0x0080, 0x0000.

## 3.1.5. 5 (0x05) Write Single Coil

This function code is used to write a single output to either ON or OFF in a remote device. The requested ON/OFF state is specified by a constant in the request data field. A value of FF 00 hex requests the output to be ON. A value of 00 00 requests it to be OFF. All other values are illegal and will not affect the output.

- **Request**

Field name	Example
Function Code	0x05
Output Address Hi	0x10
Output Address Lo	0x01
Output Value Hi	0xFF
Output Value Lo	0x00

- **Response**

Field name	Example
Function Code	0x05
Output Address Hi	0x10
Output Address Lo	0x01
Output Value Hi	0xFF
Output Value Lo	0x00

- Output bit of address 0x1001 turns ON.



# Specification

## 3.1.6. 6 (0x06) Write Single Register

This function code is used to write a single holding register in a remote device. Therefore register numbered 1 is addressed as 0. The normal response is an echo of the request, returned after the register contents have been written.

- **Request**

Field name	Example
Function Code	0x06
Register Address Hi	0x08
Register Address Lo	0x00
Register Value Hi	0x11
Register Value Lo	0x22

- **Response**

Field name	Example
Function Code	0x06
Register Address Hi	0x08
Register Address Lo	0x00
Register Value Hi	0x11
Register Value Lo	0x22

- In case of address 0x0800 output register value: 0x0000 changes to 0x1122.

## 3.1.7. 8 (0x08) Diagnostics

MODBUS function code 08 provides a series of tests for checking the communication system between a client ( Master) device and a server ( Slave), or for checking various internal error conditions within a server.

The function uses a two-byte sub-function code field in the query to define the type of test to be performed. The server echoes both the function code and sub-function code in a normal response. Some of the diagnostics cause data to be returned from the remote device in the data field of a normal response.

- **Request**

Field name	Example
Function Code	0x08
Sub-Function Hi	0x00
Sub-Function Lo	0x00
Data Hi	0x11
Data Lo	0x22

- **Response**

Field name	Example
Function Code	0x08
Sub-Function Hi	0x00
Sub-Function Lo	0x00
Data Hi	0x11
Data Lo	0x22

# Specification

## Sub-function 0x0000(0) Return Query Data

The data passed in the request data field is to be returned (looped back) in the response.

The entire response message should be identical to the request.

Sub-function	Data Field (Request)	Data Field (Response)	Description
0x0000(0)	Any	Echo Request Data	

## Sub-function 0x0001(1) Restart Communications Option

The remote device could be initialized and restarted, and all of its communications event counters are cleared.

Especially, data field 0x55AA make the remote device to restart with factory default setup of EEPROM.

Sub-function	Data Field (Request)	Data Field (Response)	Description
0x0001(1)	0x0000 or 0xFF00	Echo Request Data	Reset
0x0001(1)	0x55AA	Echo Request Data	Reset with Default Setting <sup>1)</sup>
0x0001(1)	0x55AA+0xAB7B+Sumcheck <sup>4)</sup>	Echo Request Data	Reset with Factory default <sup>2)</sup>
0x0001(1)	0x55AA+0xAA55+Sumcheck <sup>4)</sup>	Echo Request Data	Reset with Factory default <sup>3)</sup>

1),2),3) All expansion slot configuration parameters are cleared.

2),3) IP Address, Subnet Mask Address, Gateway Address, RS232/485 setting, and Bootp/DHCP mode will be the factory defaults value.

3) Mac Address will be the factory default value.

4) Refer to 3.2.2 for Sumcheck (0x1006)

## Sub-function 0x000A(10) Clear Counters and Diagnostic Register

The goal is to clear all counters and the diagnostic register. Counters are also cleared upon power-up.

Sub-function	Data Field (Request)	Data Field (Response)	Description
0x000A(10)	0x0000	Echo Request Data	

## Sub-function 0x000B(11) Return Bus Message Count

The response data field returns the quantity of messages that the remote device has detected on the communications system since its last restart, clear counters operation, or power-up.

Sub-function	Data Field (Request)	Data Field (Response)	Description
0x000B(11)	0x0000	Total Message Count	

# Specification

## Sub-function 0x000D(13) Return Bus Exception Error Count

The response data field returns the quantity of MODBUS exception responses returned by the remote device since its last restart, clear counters operation, or power-up.

Exception responses are described and listed in section 3.2.11.

Sub-function	Data Field (Request)	Data Field (Response)	Description
0x000D(13)	0x0000	Exception Error Count	

## Sub-function 0x000E(14) Return Slave Message Count

The response data field returns the quantity of messages addressed to the remote device, or broadcast, that the remote device has processed since its last restart, clear counters operation, or power-up.

Sub-function	Data Field (Request)	Data Field (Response)	Description
0x000E(14)	0x0000	Slave Message Count	

## Sub-function 0x000F(15) Return Slave No Response Count

The response data field returns the quantity of messages addressed to the remote device for which it has returned no response (neither a normal response nor an exception response), since its last restart, clear counters operation, or power-up.

Sub-function	Data Field (Request)	Data Field (Response)	Description
0x000F(15)	0x0000	Slave No Response Count	

## Sub-function 0x0064(100) Return Slave ModBus, Expansion Status

The response data field returns the status of ModBus and expansion addressed to the remote device.

This status values are identical with status 1word of input process image.

Sub-function	Data Field (Request)	Data Field (Response)	Description
0x0064(100)	0x0000	ModBus, G-Bus Status	Same as status 1word

# Specification

### 3.1.8. 15 (0x0F) Write Multiple Coils

This function code is used to force each coil in a sequence of coils to either ON or OFF in a remote device. The Request PDU specifies the coil references to be forced. Coils are addressed starting at zero. A logical '1' in a bit position of the field requests the corresponding output to be ON. A logical '0' requests it to be OFF.

The normal response returns the function code, starting address, and quantity of coils forced.

- **Request**

Field name	Example
Function Code	0x0F
Starting Address Hi	0x10
Starting Address Lo	0x00
Quantity of Outputs Hi	0x00
Quantity of Outputs Lo	0x0A
Byte Count	0x02
Output Value#0	0x55
Output Value#1	0x01

- **Response**

Field name	Example
Function Code	0x0F
Starting Address Hi	0x10
Starting Address Lo	0x00
Quantity of Outputs Hi	0x00
Quantity of Outputs Lo	0x0A

- In case of address 0x1015~0x1000 output bit value: 00000000\_00000000 changes to 00000001\_01010101.

### 3.1.9. 16 (0x10) Write Multiple Resgisters

This function code is used to write a block of contiguous registers (1 to approx. 120 registers) in a remote device.

The requested written values are specified in the request data field. Data is packed as two bytes per register.

The normal response returns the function code, starting address, and quantity of registers written.

- **Request**

Field name	Example
Function Code	0x0F
Starting Address Hi	0x10
Starting Address Lo	0x08
Quantity of Registers Hi	0x00
Quantity of Registers Lo	0x02
Byte Count	0x04
Register Value#0 Hi	0x11
Register Value#0 Lo	0x22
Register Value#1 Hi	0x33
Register Value#1 Lo	0x44

# Specification

- **Response**

Field name	Example
Function Code	0x0F
Starting Address Hi	0x10
Starting Address Lo	0x08
Quantity of Registers Hi	0x00
Quantity of Registers Lo	0x02

- In case of address 0x0800, 0x0801 output register value: 0x0000, 0x0000 changes to 0x1122, 0x3344.

### 3.1.10. 23 (0x17) Read/Write Multiple Registers

This function code performs a combination of one read operation and one write operation in a single MODBUS transaction. The write operation is performed before the read. The request specifies the starting address and number of holding registers to be read as well as the starting address, number of holding registers, and the data to be written. The byte count specifies the number of bytes to follow in the write data field.

The normal response contains the data from the group of registers that were read. The byte count field specifies the quantity of bytes to follow in the read data field.

- **Request**

Field name	Example
Function Code	0x17
Read Starting Address Hi	0x08
Read Starting Address Lo	0x00
Quantity of Read Hi	0x00
Quantity of Read Lo	0x02
Write Starting Address Hi	0x08
Write Starting Address Lo	0x00
Quantity of Write Hi	0x00
Quantity of Write Lo	0x02
Byte Count	0x04
Write Reg. Value#0 Hi	0x11
Write Reg. Value#0 Lo	0x22
Write Reg. Value#1 Hi	0x33
Write Reg. Value#1 Lo	0x44

- **Response**

Field name	Example
Function Code	0x17
Byte Count	0x04
Read Reg. Value#0 Hi	0x11
Read Reg. Value#0 Lo	0x22
Read Reg. Value#1 Hi	0x33
Read Reg. Value#1 Lo	0x44

- In case of address 0x0800, 0x0801 output register value: 0x0000, 0x0000 changes to 0x1122, 0x3344.

# Specification

## 3.1.11. Error Response

In an exception response, the server sets the MSB of the function code to 1. This makes the function code value in an exception response exactly 80 hexadecimal higher than the value would be for a normal response.

- **Exception Response Example**

Field name	Example
Function Code	0x81
Exception Code	0x02

- **Exception Codes**

Exception Code	Name	Description
01	Illegal Function	The function code received in the query is not an allowable action for the server (or slave).
02	Illegal Data Address	The data address received in the query is not an allowable address for the server (or slave).
03	Illegal Data Value	A value contained in the query data field is not an allowable value for server (or slave).
04	Slave Device Failure	An unrecoverable error occurred while the server (or slave) was attempting to perform the requested action.
06	Slave Device Busy	Specialized use in conjunction with programming commands. The server (or slave) is engaged in processing a long-duration program command. The client (or master) should retransmit the message later when the server (or slave) is free.

# Specification

## 3.2. MODBUS Special Register Map

The special register map can be accessed by function code 3, 4, 6 and 16. Also the special register map must be accessed by read/write of every each address (one address).

### 3.2.1. Adapter Resgister Mapping

Address	IEC Address	Contents	Remarks
0x0000~0x07FF	%IW0~%IW2047	2048 words Input and Internal memory (Area is write-protected)	
0x0800~0x0FFF	%QW0~%QW2047	2048 words Output and Internal memory (Area is write-enabled)	
0x1000~0x1FFF	-	Special Function Register (PIO Information)	
0x2000~0x2FFF	-	Special Function Register (Slot Information)	
0x4000~0x5FFF	%MW0~%MW8191	8192 words Internal memory (Area is write-enabled)	

### 3.2.2. Adapter Identification Special Resgister (0x1000, 4096)

Address	Access	Type, Size	Description
0x1000(4096)	Read	1word	Vendor ID = 0x02E5(741), Crevis. Co., Ltd.
0x1001(4097)	Read	1word	Device type = 0x000C, Network Adapter
0x1002(4098)	Read	1word	Product Code = 0x9100(GN-9371) / 0x9110(GN-9372) / 0x9120(GN-9373)
0x1003(4099)	Read	1word	Firmware revision, if 0x0101, revision 1.001
0x1005(4101)	Read	String upto 34bytes	Product name string First 1word is length of valid character string Example) response as following "00 1D 52 4E 2D 39 32 32 32 2C 50 72 6F 66 69 62 75 73 20 41 64 61 70 74 65 72 2C 52 42 55 53 00 00 000" Valid character size = 0x0017 =29 characters "GN-9372(PIO)"
0x1006(4102)	Read	1word	Sum check of EEPROM
0x1010(4112)	Read	2words	Firmware release date
0x101E(4126)	Read	15words	Composite Id of following address 0x1600(5632),0x1602(5634),0x1604(5636),0x16105648), 0x1000(4096),0x1001(4097),0x1002(4098),0x1003(4099),0x1010(4112)

- String Type consists of valid string length (first 1word) and array of characters

# Specification

## 3.2.3. Adapter Information Special Register (0x1100, 4352)

Address	Access	Type, Size	Description
0x1102(4354)	Read	1word	Start address of input image word register. =0x0000
0x1103(4355)	Read	1word	Start address of output image word register. =0x0800
0x1104(4356)	Read	1word	Size of input image word register.
0x1105(4357)	Read	1word	Size of output image word register.
0x1106(4358)	Read	1word	Start address of input image bit. = 0x0000
0x1107(4359)	Read	1word	Start address of output image bit. =0x1000
0x1108(4360)	Read	1word	Size of input image bit.
0x1109(4361)	Read	1word	Size of output image bit.
0x110D(4365)	Read	1word	Field Power On/Off, Run/Stop Switch On/Off, Reset Switch On/Off check
0x110E(4366)	Read	upto 64words	Expansion slot's GT-number including NA First 1word is adapter's number, if GN-9372, then 0x9372
0x1110(4368)	Read	1word	Number of expansion slot
0x1111(4369)	Read	1word	Number of active slot
0x1112(4370)	Read	1word	Number of inactive slot
0x1113(4371)	Read	upto 64words	Expansion slot Module Id. Refer to Appendix A.1 Product List. First 1word is adapter's module id.
0x1116(4374) *	Read/Write	4words	Inactive slot list, The corresponding bit represents slot position. 0:Active slot, 1:Inactive slot. Ex) if value is 0x0001, 0x8000, then slot#1,#16 are inactive slots
0x1117(4375)	Read	4words	Live slot list. , The corresponding bit represents slot position. 1:live slot, 0:not live slot
0x1118(4376)	Read	4words	Alarm slot list. The corresponding bit represents slot position. 1:Alarm slot, 0:Normal slot
0x1119(4377)	Read	1word	Hi byte is ModBus status, low byte is internal status. Zero value mean 'no error'
0x111D(4381)	Read	1word	Adapter G-Bus Revision. If 0x0200, G-Series Revision is 2.00
0x111E(4382)	Read	1word	Reserved. Adapter IO identification vendor code.

\* If the slot location is changed, set default value automatically (all expansion slot are live).

\* After the system is reset, the new "Set Value" action is applied.



# Specification

## 3.2.4. Adapter Setting Special Register (0x1600, 5632)

Address	Access	Type, Size	Description
0x1600(5632)	Read	2words	IP Address. (ex : A8C0 6464 = 192.168.100.100)
0x1602(5634)	Read	2words	Subnet Mask. (ex : FFFF 0000 = 255.255.0.0)
0x1604(5636)	Read	2words	Gate way. (ex : A8C0 0100 = 192.168.0.1)
0x1606(5638)	Read/Write	1word	RS-232C Baudrate. (2400bps~115200bps) - 0 : 115200 (default) - 1 : 2400 - 2 : 4800 - 3 : 9600 - 4 : 19200 - 5 : 38400 - 6 : 57600 - 7 : 115200
0x1607(5639)	Read/Write	1word	*RS-232C Setting. - 1 nibble : Data bit(0 : 8bit(default), 1 : 9bit) - 2 nibble : Stop bit(0 : 1bit(default), 1 : 2bit) - 3 nibble : Parity bit(0 : none(default), 1: odd, 2 : even) - 4 nibble : Reserve
0x1608(5640)	Read/Write	1word	RS-485 Baudrate. (2400bps~115200bps) - 0 : 115200 (default) - 1 : 2400 - 2 : 4800 - 3 : 9600 - 4 : 19200 - 5 : 38400 - 6 : 57600 - 7 : 115200
0x1609(5641)	Read/Write	1word	RS-485 Setting. - 1 nibble : Data bit(0 : 8bit(default), 1 : 9bit) - 2 nibble : Stop bit(0 : 1bit(default), 1 : 2bit) - 3 nibble : Parity bit(0 : none(default), 1: odd, 2 : even) - 4 nibble : Reserve
0x160A(5642)	Read/Write	1word	**Modbus Station. - High 1byte : Station No. of RS-232C (default : 1) - Low 1byte : Station No. of RS-485 (default : 1)
0x160B(5643)	Read/Write	1word	IP Setting Method. - BootP/DHCP disable: 0x0000 - BootP : 0x8000 (default) - DHCP : 0x8001
0x1610(5648)	Read	3words	Mac Address (ex : 1400 00F7 0101 = 00.14.F7.00.01.01)
0x1614(5652)*	Read/Write	1word	Serial connection Method - 0x0000 : Crevis Modbus/RTU (default) - 0x8000 : RS232 Enable for CoDeSys Function block / RTU Master - 0x8001 : RS485 Enable for CoDeSys Function block / RTU Master
0x1620(5664)	Read/Write	4words	RTC - 1 word : 00ss (ss : sec) - 2 word : hhmm (hh : hour, mm : min) - 3 word : mmdd (mm : month, dd : day) - 4 word : yyyy (yyyy : year) (ex : 0010 0F28 0317 07E0 = 2016 - 03.23 - 15:40 - 16)

\* 0x1614 is not supported for GN-9371

# Specification

**\*RS-232C/485 Setting :** This description for 0x1607/0x1609 register with bit.

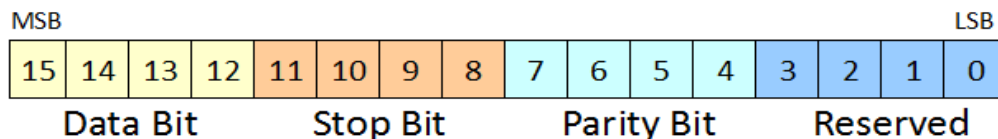

**\*\*Modbus Station :** This description for 0x160A register with bit.

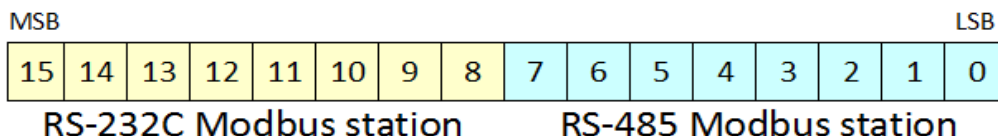

### 3.2.5. Expansion Slot Information Special Resister (0x2000, 8192)

Each expansion slot has 0x40(64) address offset and same information structure.

Slot#1	0x2000(8192)~0x201F(8223)	Slot#2	0x2020(8224)~0x203F(8255)
Slot#3	0x2040(8256)~0x205F(8287)	Slot#4	0x2060(8288)~0x207F(8319)
Slot#5	0x2080(8320)~0x209F(8351)	Slot#6	0x20A0(8352)~0x20BF(8383)
Slot#7	0x20C0(8384)~0x20DF(8415)	Slot#8	0x20E0(8416)~0x20FF(8447)
Slot#9	0x2100(8448)~0x211F(8479)	Slot#10	0x2120(8480)~0x213F(8511)
Slot#11	0x2140(8512)~0x215F(8543)	Slot#12	0x2160(8544)~0x217F(8575)
Slot#13	0x2180(8576)~0x219F(8607)	Slot#14	0x21A0(8608)~0x21BF(8639)
Slot#15	0x21C0(8640)~0x21DF(8671)	Slot#16	0x21E0(8672)~0x21FF(8703)
Slot#17	0x2200(8704)~0x221F(8735)	Slot#18	0x2220(8736)~0x223F(8767)
Slot#19	0x2240(8768)~0x225F(8799)	Slot#20	0x2260(8800)~0x227F(8831)
Slot#21	0x2280(8832)~0x229F(8863)	Slot#22	0x22A0(8864)~0x22BF(8895)
Slot#23	0x22C0(8896)~0x22DF(8927)	Slot#24	0x22E0(8928)~0x22FF(8959)
Slot#25	0x2300(8960)~0x231F(8991)	Slot#26	0x2320(8992)~0x233F(9023)
Slot#27	0x2340(9024)~0x235F(9055)	Slot#28	0x2360(9056)~0x237F(9087)
Slot#29	0x2380(9088)~0x239F(9119)	Slot#30	0x23A0(9120)~0x23BF(9151)
Slot#31	0x23C0(9152)~0x23DF(9183)	Slot#32	0x23E0(9184)~0x23FF(9215)
Slot#33	0x2400(9216)~0x241F(9247)	Slot#34	0x2420(9248)~0x243F(9279)
Slot#35	0x2440(9280)~0x245F(9311)	Slot#36	0x2460(9312)~0x247F(9343)
Slot#37	0x2480(9344)~0x249F(9375)	Slot#38	0x24A0(9376)~0x24BF(9407)
Slot#39	0x24C0(9408)~0x24DF(9439)	Slot#40	0x24E0(9440)~0x24FF(9471)
Slot#41	0x2500(9472)~0x251F(9503)	Slot#42	0x2520(9504)~0x253F(9535)
Slot#43	0x2540(9536)~0x255F(9567)	Slot#44	0x2560(9568)~0x257F(9599)
Slot#45	0x2580(9600)~0x259F(9631)	Slot#46	0x25A0(9632)~0x25BF(9663)
Slot#47	0x25C0(9664)~0x25DF(9695)	Slot#48	0x25E0(9696)~0x25FF(9727)
Slot#49	0x2600(9728)~0x261F(9759)	Slot#50	0x2620(9760)~0x263F(9791)
Slot#51	0x2640(9792)~0x265F(9823)	Slot#52	0x2660(9824)~0x267F(9855)
Slot#53	0x2680(9856)~0x269F(9887)	Slot#54	0x26A0(9888)~0x26BF(9919)
Slot#55	0x26C0(9920)~0x26DF(9951)	Slot#56	0x26E0(9952)~0x26FF(9983)
Slot#57	0x2700(9984)~0x271F(10015)	Slot#58	0x2720(10016)~0x273F(10047)
Slot#59	0x2740(10048)~0x275F(10079)	Slot#60	0x2760(10080)~0x277F(10111)
Slot#61	0x2780(10112)~0x279F(10143)	Slot#62	0x27A0(10144)~0x27BF(10175)
Slot#63	0x27C0(10176)~0x27DF(10207)		

# Specification

Address Offset	Expansion Slot#1	Expansion Slot#2	Expansion Slot#3	.....	Expansion Slot#62	Expansion Slot#63
+ 0x00(+0)	0x2000(8192)	0x2020(8224)	0x2040(8256)	.....	0x27A0(9120)	0x27C0(9152)
+ 0x01(+1)	0x2001(8193)	0x2021(8225)	0x2041(8257)	.....	0x27A1(9121)	0x27C1(9153)
+ 0x02(+2)	0x2002(8194)	0x2022(8226)	0x2042(8258)	.....	0x27A2(9122)	0x27C2(9154)
+ 0x03(+3)	0x2003(8195)	0x2023(8227)	0x2043(8259)	.....	0x27A3(9123)	0x27C3(9155)
+ 0x04(+4)	0x2004(8196)	0x2024(8228)	0x2044(8260)	.....	0x27A4(9124)	0x27C4(9156)
+ 0x05(+5)	0x2005(8197)	0x2025(8229)	0x2045(8261)	.....	0x27A5(9125)	0x27C5(9157)
+ 0x06(+6)	0x2006(8198)	0x2026(8230)	0x2046(8262)	.....	0x27A6(9126)	0x27C6(9158)
+ 0x07(+7)	0x2007(8199)	0x2027(8231)	0x2047(8263)	.....	0x27A7(9127)	0x27C7(9159)
+ 0x08(+8)	0x2008(8200)	0x2028(8232)	0x2048(8264)	.....	0x27A8(9128)	0x27C8(9160)
+ 0x09(+9)	0x2009(8201)	0x2029(8233)	0x2049(8265)	.....	0x27A9(9129)	0x27C9(9161)
+ 0x0A(+10)	0x200A(8202)	0x202A(8234)	0x204A(8266)	.....	0x27AA(9130)	0x27CA(9162)
+ 0x0B(+11)	0x200B(8203)	0x202B(8235)	0x204B(8267)	.....	0x27AB(9131)	0x27CB(9163)
+ 0x0C(+12)	0x200C(8204)	0x202C(8236)	0x204C(8268)	.....	0x27AC(9132)	0x27CC(9164)
+ 0x0D(+13)	0x200D(8205)	0x202D(8237)	0x204D(8269)	.....	0x27AD(9133)	0x27CD(9165)
+ 0x0E(+14)	0x200E(8206)	0x202E(8238)	0x204E(8270)	.....	0x27AE(9134)	0x27CE(9166)
+ 0x0F(+15)	0x200F(8207)	0x202F(8239)	0x204F(8271)	.....	0x27AF(9135)	0x27CF(9167)
+ 0x10(+16)	0x2010(8208)	0x2030(8240)	0x2050(8272)	.....	0x27B0(9136)	0x27D0(9168)
+ 0x11(+17)	0x2011(8209)	0x2031(8241)	0x2051(8273)	.....	0x27B1(9137)	0x27D1(9169)
+ 0x12(+18)	0x2012(8210)	0x2032(8242)	0x2052(8274)	.....	0x27B2(9138)	0x27D2(9170)
+ 0x13(+19)	0x2013(8211)	0x2033(8243)	0x2053(8275)	.....	0x27B3(9139)	0x27D3(9171)
+ 0x14(+20)	0x2014(8212)	0x2034(8244)	0x2054(8276)	.....	0x27B4(9140)	0x27D4(9172)
+ 0x15(+21)	0x2015(8213)	0x2035(8245)	0x2055(8277)	.....	0x27B5(9141)	0x27D5(9173)
+ 0x16(+22)	0x2016(8214)	0x2036(8246)	0x2056(8278)	.....	0x27B6(9142)	0x27D6(9174)
+ 0x17(+23)	0x2017(8215)	0x2037(8247)	0x2057(8279)	.....	0x27B7(9143)	0x27D7(9175)
+ 0x18(+24)	0x2018(8216)	0x2038(8248)	0x2058(8280)	.....	0x27B8(9144)	0x27D8(9176)
+ 0x19(+25)	0x2018(8217)	0x2038(8249)	0x2058(8281)	.....	0x27B9(9145)	0x27D9(9177)
+ 0x1A(+26)	0x201A(8218)	0x203A(8250)	0x205A(8282)	.....	0x27BA(9146)	0x27DA(9178)
+ 0x1B(+27)	0x201B(8219)	0x203B(8251)	0x205B(8283)	.....	0x27BB(9147)	0x27DB(9179)
+ 0x1C(+28)	0x201C(8220)	0x203C(8252)	0x205C(8284)	.....	0x27BC(9148)	0x27DC(9180)
+ 0x1D(+29)	0x201D(8221)	0x203D(8253)	0x205D(8285)	.....	0x27BD(9149)	0x27DD(9181)
+ 0x1E(+30)	0x201E(8222)	0x203E(8254)	0x205E(8286)	.....	0x27BE(9150)	0x27DE(9182)
+ 0x1F(+31)	0x201F(8223)	0x203F(8255)	0x205F(8287)	.....	0x27BF(9151)	0x27DF(9183)

Address Offset	Access	Type, Size	Description
+ 0x00(+0)	Read	1 word	Slot module id.
+ 0x01(+1)	Read	1 word	Expansion Slot IO code. Refer to Table IO Data Code Format.
+ 0x02(+2) **	Read	1 word	Input start register address of input image word this slot.
+ 0x03(+3) **	Read	1 word	Input word's bit offset of input image word this slot.
+ 0x04(+4) **	Read	1 word	Output start register address of output image word this slot.
+ 0x05(+5) **	Read	1 word	Output word's bit offset of output image word this slot.
+ 0x06(+6) **	Read	1 word	Input bit start address of input image bit this slot.
+ 0x07(+7) **	Read	1 word	Output bit start address of output image bit this slot.
+ 0x08(+8) **	Read	1 word	Size of input bit this slot
+ 0x09(+9) **	Read	1 word	Size of output bit this slot
+ 0x0A(+10)**	Read	n word	Read input data this slot
+ 0x0B(+11)**	Read/Write	n word	Read/write output data this slot
+ 0x0C(+12) *	Read/Write	1 word	Inactive slot, 0x0000:active, 0x0001:inactive
+ 0x0E(+14)	Read	1 word	GT-number, if GT-1238, returns 0x1238

# Specification

+ 0x0F(+15)	Read	String upto 72bytes	First 1word is length of valid character string. If GT-1238, returns “00 1E 52 54 2D 31 32 33 38 2C 20 38 44 49 2C 20 32 34 56 64 63 2C 20 55 6E 69 76 65 72 73 61 6C 00 00” Valid character size = 0x001E =30 characters, “GT-1218, 8DI, 24Vdc, Sink/Source”
+ 0x10(+16)	Read	1word	Size of configuration parameter byte
+ 0x11(+17)**	Read/Write	n word	Read/write Configuration parameter data, up to 8byte. ***
+ 0x12(+18)	Read	1word	Size of memory byte.
+ 0x13(+19)**	Read/Write	n word	Read/write Memory data. Offset of memory is fixed with 0
+ 0x14(+20)**	Read/Write	n word	Read/write Memory data. First 2byte of write data is memory offset.
+ 0x15(+21)	Read	2words	Product code.
+ 0x16(+22)	Read	2words	Catalog number.
+ 0x17(+23)	Read	1word	Firmware Revision
+ 0x18(+24)	Read	1word	G-Bus Revision

\* After the system is reset, the new “Set Value” action is applied.

\*\* Nothing of output, input, memory or configuration parameter corresponding slot returns Exception 02.

\*\*\* Slot Configuration parameter saved by internal EEPROM during power cycle until slot position changed.

\*\*\* All of output modules and special modules have the slot configuration parameter data.

Table 3.3.1. IO Data Code Format (1word)

Item	#15	#14	#13	#12	#11	#10	#9	#8	#7	#6	#5	#4	#3	#2	#1	#0	Word
Field	Output IO code								Input IO code								
Field	Date Type		Data Length						Data Type		Data Length						
<b>Example)</b>																	
GT-3424	0	0	0	0	0	0	0	0	1	0	0	0	0	1	0	0	0x0084
GT-1238	0	0	0	0	0	0	0	0	1	1	0	0	0	1	0	0	0x00C4
GT-1804	0	0	0	0	0	0	0	0	1	1	0	0	1	0	0	0	0x00C8
GT-442F	1	0	0	0	0	1	0	0	0	0	0	0	0	0	0	0	0x8400
GT-221F	1	1	0	1	0	0	0	0	0	0	0	0	0	0	0	0	0xD000
GT-2328	1	1	0	0	0	1	0	0	0	0	0	0	0	0	0	0	0xC400

### Input/Output Data Type :

0 0: No I/O Data

0 1: Byte Data

1 0: Word Data

1 1: Bit Data

### Input/Output Data Length:

0 0 0 0 0 0 : 0 Bit/Byte/Word

0 0 0 0 0 1 : 1 Bit/Byte/Word

0 0 0 0 1 0 : 2 Bit/Byte/Word

0 0 0 0 1 1 : 3 Bit/Byte/Word

...

1 1 1 1 1 1 : 63 Bit/Byte/Word

---

## 3.3. Supported MODBUS Function Codes

MODBUS Reference Documents

<http://www.modubs.org>

MODBUS Tools

<http://www.modbustools.com>, modbus poll

<http://www.win-tech.com>, modscan32